

REV.	DATE	REVISION DESCRIPTION	PCN NO.
A	28/11/00	UPDATED DRAWING	00-56

NOTE:
200 PSI MAX. WORKING PRESSURE AT 650 DEG.
NATIONAL BOARD & C.R.N. APPROVED
PAINTED DEVAIR ORANGE

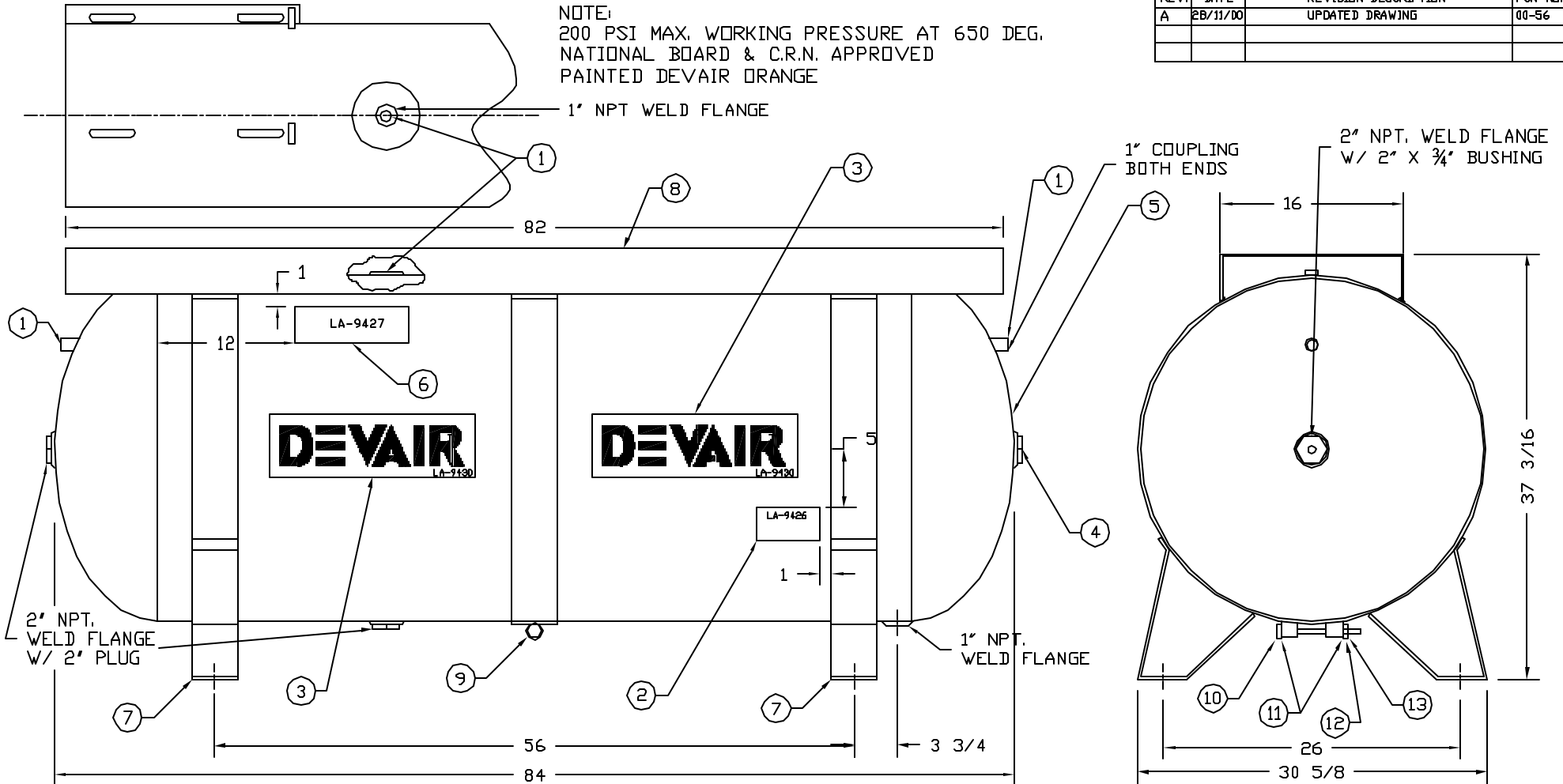

NO.	PART NO.	DESCRIPTION	QTY	PART NO.	DESCRIPTION
1	SS-3185	1' THREAD PROTECTOR (3)	9	VAX-9408	COMPRESSOR BASE
2	LA-9426	DRAIN DAILY LABEL	9	VAX-9409	STRAP ASSEMBLY
3	LA-9430	DEVAIR DECAL, 5 1/2" X 18" (2)	10	SS-00409	1/2-13 X 7' LG HHCS (3)
4	SS-3184	3/4' THREAD PROTECTOR	11	SS-1527	1/2" WTR WASHER (6)
5	TA-9003-2	BARE TANK ONLY, NO FEET/BASE	12	SS-1506	1/2" MEDIUM LOCK WASHER (3)
6	LA-9427	CAUTION LABEL	13	SS-659	1/2"-13 HEX. NUT (3)
7	VAX-9407	STRAP AND FOOT ASSEMBLY (2)			

IMPORTANT NOTE: This print is the confidential property of DEVAIR, INC. It is not to be used or reproduced in any manner, nor submitted to other parties for examination without the prior approval of DEVAIR, INC.

FRACTIONAL DIMENSIONS: ±1/32
DECIMAL DIMENSION: ±.005
ANGLES: ±1°
*UNLESS OTHERWISE SPECIFIED

DEVAIR

NAME OF PROJECT			DESCRIPTION OF DRAWING	
240 GAL. HORIZONTAL AIR RECEIVER			REMOTE TANK	
DRAWN BY	CHECKED BY	DATE	SCALE	DRAWING NO.
ADAM SMITH		NOV 20/00	N.T.S.	TA-9498
				SHT NO
				REV
				A