

**AIR COMPRESSOR SPECIFICATION:**

The compressor unit shall incorporate a V belt driven, OMEGA heavy duty cast iron air cooled, reciprocating type air compressor complete with air intake filter silencers. The compressor pump shall be mounted on a ASME code constructed air receiver. The compressor pump will be equipped with oil site gauge. The electric motor will be 1725 rpm, open drip proof with a service factor of 1.15 and have class B insulation. The compressor base plate will be slotted for belt adjustment and the drive equipped with a OSHA type, totally enclosed belt guard. The air receiver shall be complete with pressure switch, pressure guage, ASME approved safety valve, check valve and ball type air outlet valve. A head release mechanism will be furnished with the compressor to permit load free motor starting at all times. The unit will be backed by a two year limited warranty against manufactures defects.

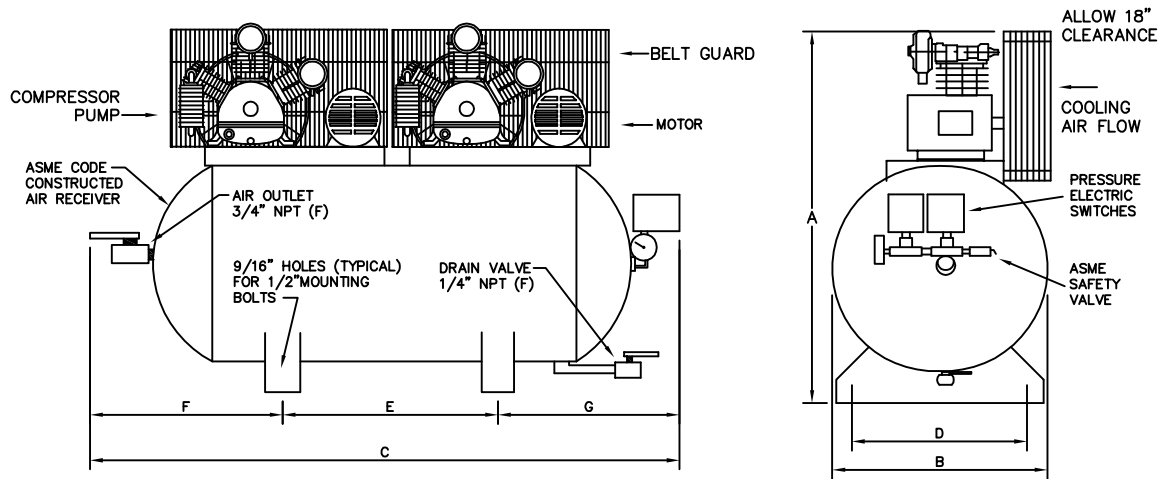

**PERFORMANCE DATA**

MODEL	HP	DELIVERY		PRESSURE SETTINGS		RECEIVER		COMPRESSOR			
		SCFM	L/S	PSIG	KPA	Gal US.	LITERS	PUMP	RPM	CYL	STGS
CC-DX-0260	2	9.2	4.34	70-90	483-620	60	227	CK-40	544	3	1

**DIMENSIONAL DATA (inches)**

MODEL	A	B	C	D	E	F	G
CC-DX-0260	45	21	61	18.75	24	19	18

**WT. DISTRIBUTION (Lbs)**

FT.1	FT.2	FT.3	FT.4	TOTAL
104	158	104	135	501

**ELECTRICAL DATA (60Hz)**

HP.	APPROX. FULL LOAD AMPS					
	Single Phase		Three Phase			
	110V.	220V.	200V.	230V.	460V.	575V.
2	25.6	12.8	6.5	6.0	3.0	2.4

BELT GUARD SIDE	
2	4
1	3

<b>OMEGA AIR COMPRESSORS</b>	<b>HVAC SERIES</b>	<b>2HP TANK MOUNTED DUPLEX COMPRESSOR</b>	<b>Print No: Dwg: Chk'd</b>	<b>ESJL33S-1 Scale: Not to. Wt Dist: +-5lbs</b>
Typical only. Data & specifications may be subject to change. May not include accessory items for any particular order.			Project Reference:	